

FLANGED DETAIL

FRAMED DETAIL

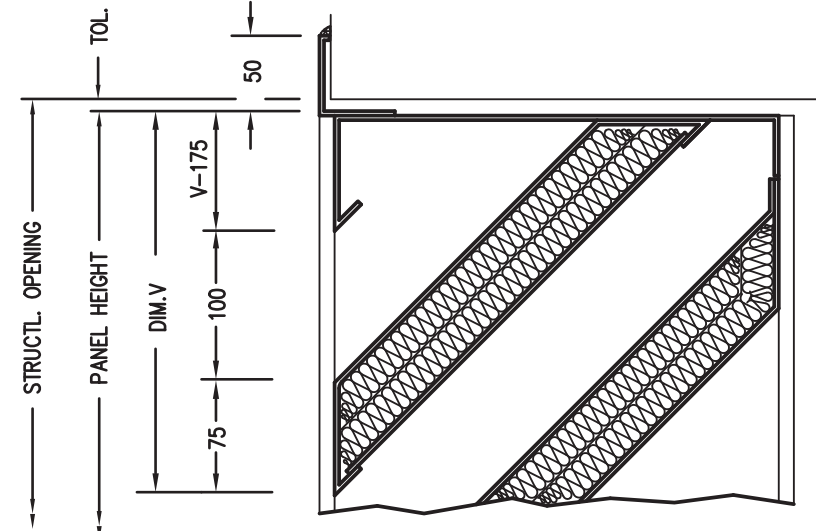

870. HEAD DETAIL

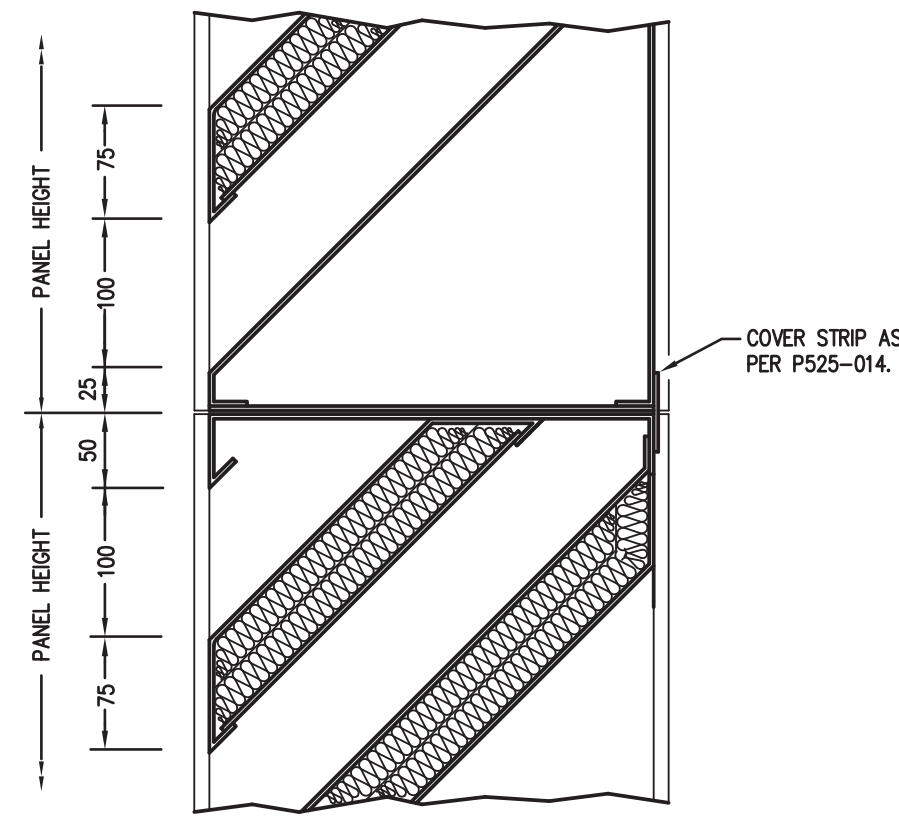

873. VERTICAL JOINT DETAIL

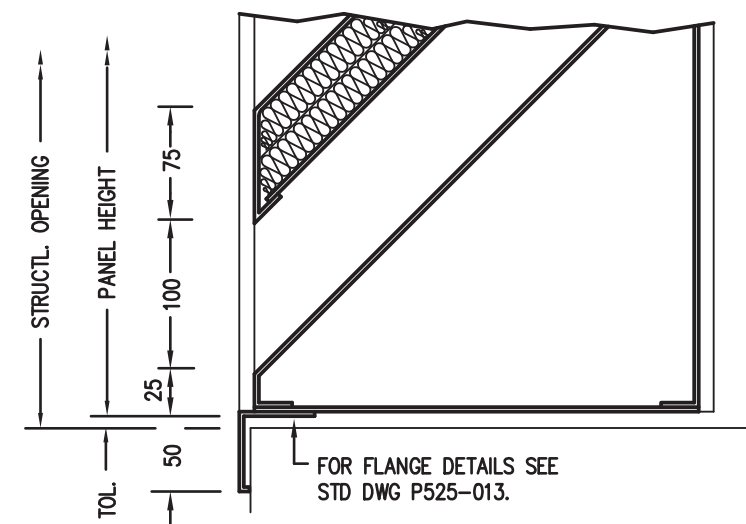

871. CILL DETAIL

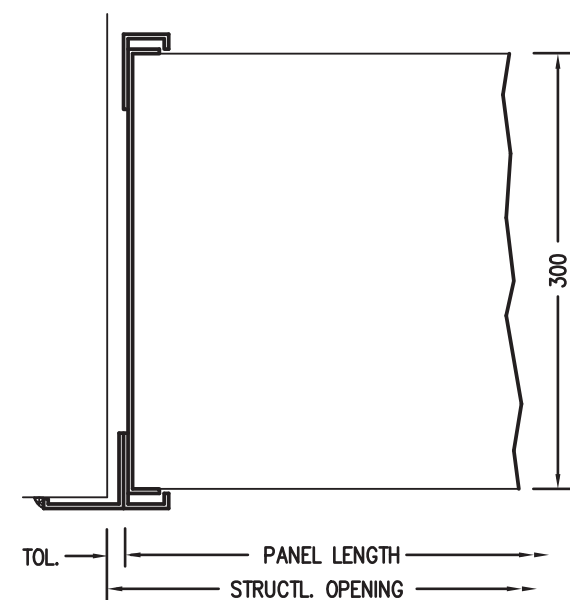

872. JAMB DETAIL

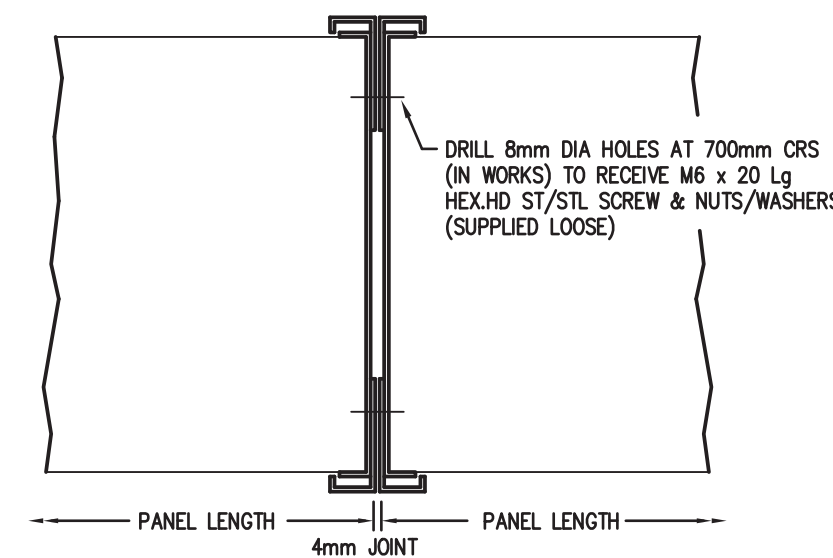

874. HORIZONTAL JOINT DETAIL

The AL Acoustic Louvre has been designed to provide broad band attenuation which is particularly effective at medium and high frequencies. The louvre blades are pitched at 175mm centres, with the top of the blade being solid metal, formed to have a rear weatherlip. The acoustic medium to the underbelly is secured by perforated metal to allow absorption of the sound waves. The louvre is designed for traditional applications; duct terminal, compressor rooms etc, but can also be used as screen (roof top or similar) since the acoustic medium does not soak up water and is rot and vermin proof. Can be used alone or placed behind other louvre systems.

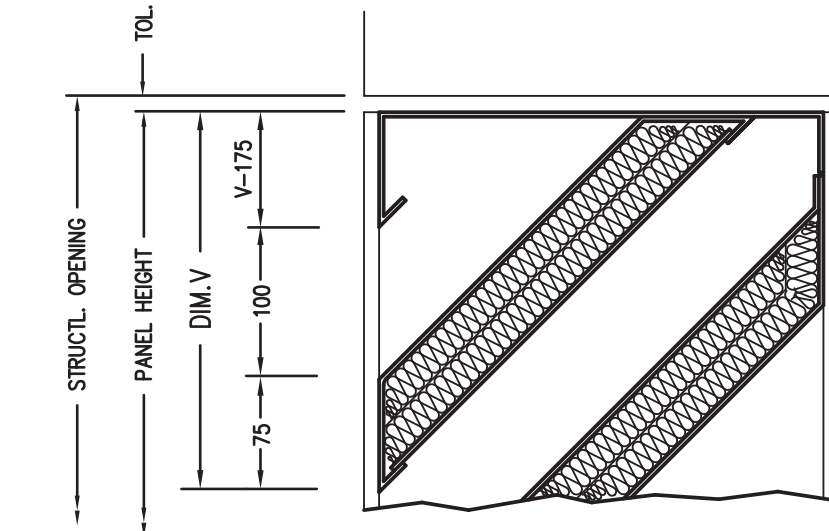

875. HEAD DETAIL

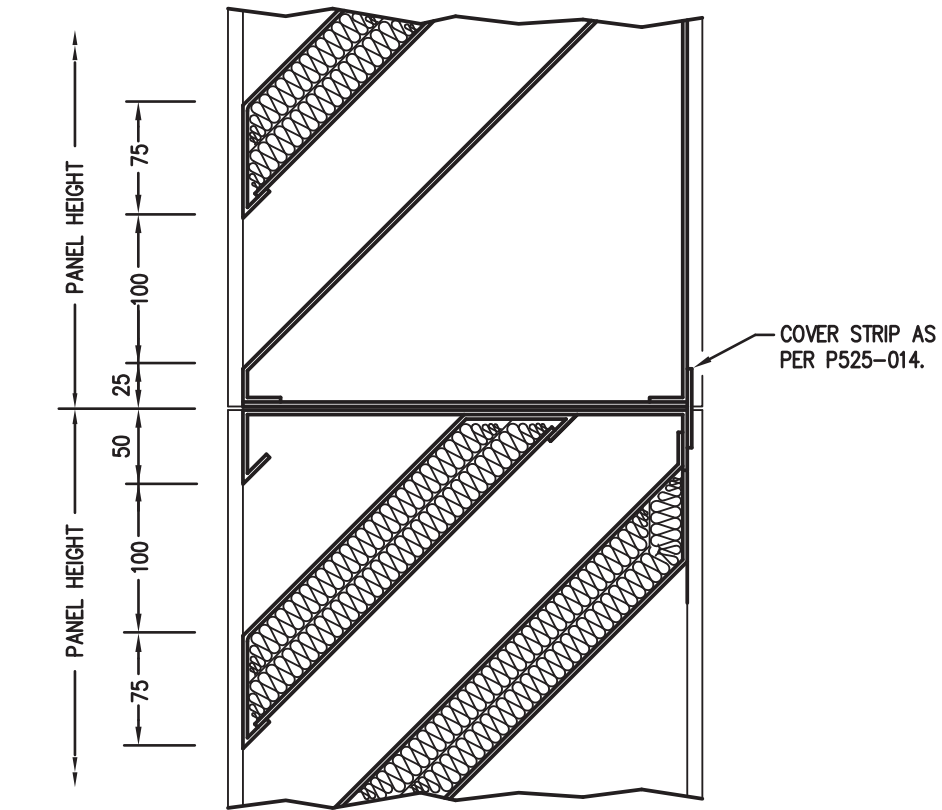

873. VERTICAL JOINT DETAIL

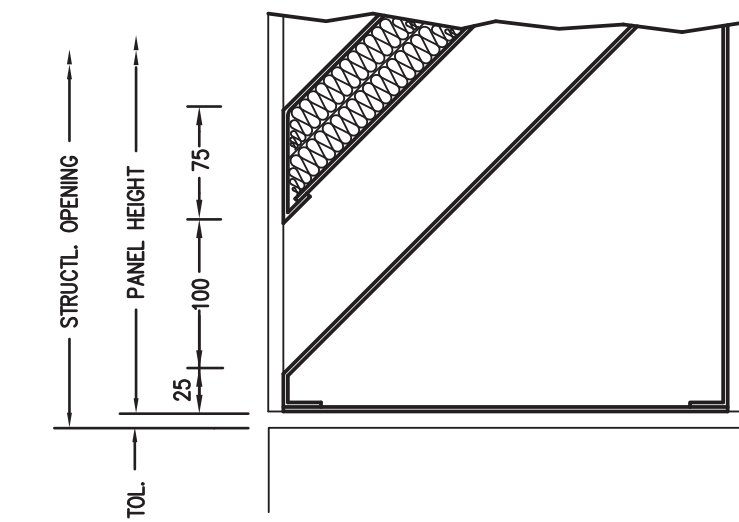

876. CILL DETAIL

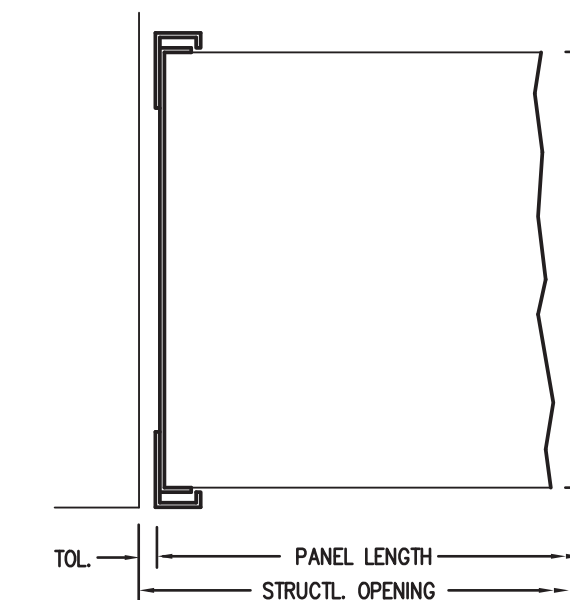

877. JAMB DETAIL

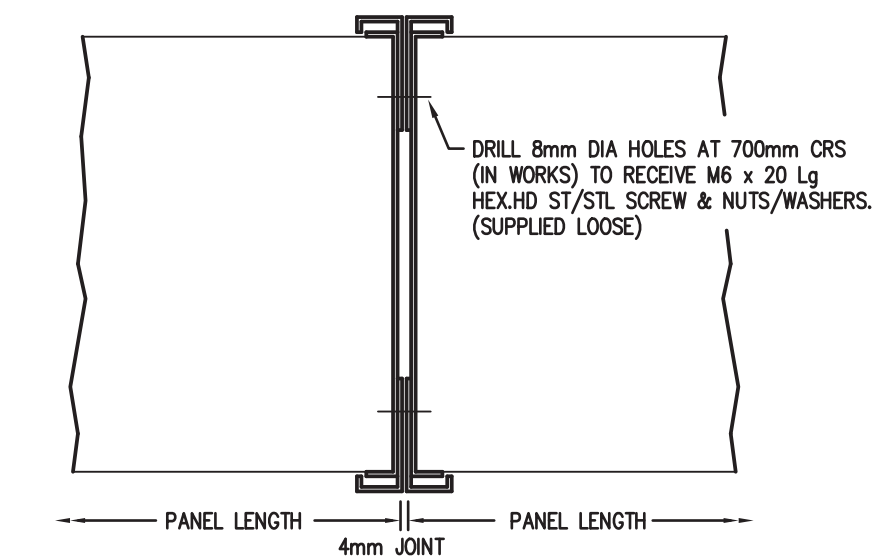

874. HORIZONTAL JOINT DETAIL

CORNER SECTION

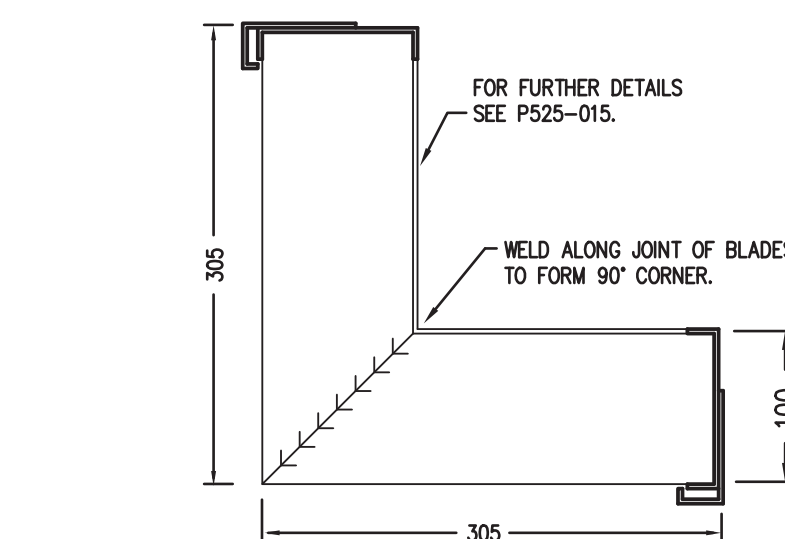

878. 90° EXTERNAL CORNER DETAIL

NOTE: The details shown within this drawing are for use as an aid only. If you are unsure which blocks are best suited for your application please contact our technical team on (0161) 763 3735 and we will be

© COPYRIGHT 2009 HUNTER PRODUCTS
THIS DRAWING & DESIGN ARE THE PROPERTY OF HUNTER PRODUCTS GROUP., AND MUST NOT BE COPIED OR USED IN ANY WAY PREJUDICIAL TO THEIR INTERESTS.

SO SUPPLY ONLY S&F SUPPLY & FIX

LOUVRE TYPE : LOUVRE_TYPE
TRIM TYPE : TRIM_TYPE
GUARD TYPE : GUARD_TYPE
PAINT TYPE : PAINT_TYPE
FINISH : FINISH
COLOUR : COLOUR
LOCATION : LOCATION
CUSTOMERS REF : CUST_REF'S
GAV REF : GAV_REF'S

DO NOT SCALE DRAWING, IF IN DOUBT ASK.
ALL DETAILS & DIMENSIONS MUST BE CONFIRMED AS CORRECT BEFORE MANUFACTURE OF LOUVRES CAN COMMENCE.
CUSTOMER DRAWINGS USED -- CUST_DRAWINGS_USED

Rev	Description	Mod. By	Date

© COPYRIGHT 2009 HUNTER PRODUCTS
THIS DRAWING & DESIGN ARE THE PROPERTY OF HUNTER PRODUCTS GROUP., AND MUST NOT BE COPIED OR USED IN ANY WAY PREJUDICIAL TO THEIR INTERESTS.

Project

Customer

Drawing Title

ALS ACOUSTIC LOUVRE

Location/Panel Ref. PANEL_LOCATION

Drawing No.	Sheet No.	Revision

Scale	DATE

Computer File No.	Project No.	CONTRACT_NO

Drawn By	Checked By	CHKED_BY

Coordinated By	Approved By	APP'VD_BY

GILL AIR

OFFICE SUITE 3, 22 BUSINESS PARK,
BRIDGE HALL LANE, BURRY, ELS 7NY
Tel: 0161 763 3735 www.gillair.net